



CONGRATULATIONS!

Thank you for choosing Aristokraft Cabinetry. To ensure the enjoyment of your cabinetry for years to come, we've prepared this guide to help you take proper care of your investment.

CABINET CLEANING

CLEANING GUIDELINES

A soft cotton cloth dampened with warm water is usually sufficient to clean your cabinets. If more thorough cleaning is required, use a fresh solution of dishwashing liquid or a mild all-purpose cleaner mixed with warm water.

Use the mildest cleaning solution that will successfully clean your cabinets. Stronger products may damage or discolor your cabinet finish and are not recommended.

After cleaning, wipe all surfaces with a clean, damp cloth. Dry immediately using another soft, clean cloth.

Clean spills and splatters immediately. Prolonged exposure to spills, including food, water or other liquids, or to oil and grease splatters, can cause permanent discoloration or damage to your cabinet finish.

REGULAR DUSTING

Use a clean, soft lint-free cotton cloth for regular dusting. Packaged dusting sheets are not required or recommended. Do not use pre-moistened dusting sheets, and do not use aerosol products made for dusting.

WAXING AND POLISHING

Waxing is not required or recommended. Over time, waxing and polishing compounds may build up on the surface of your cabinets and cause a hazy, streaky or yellowed appearance. This wax build up is very difficult to remove.

CLEANING GLASS DOORS

Extra care is required when cleaning glass doors. Spray an ammonia-free glass cleaner on a clean, soft, lint-free cloth or paper towel. Do not spray cleaner directly on the glass. It could seep behind the door mullions and cause damage.

CLEANING PRODUCTS TO AVOID

Avoid using the following cleaning products on your cabinets:

- Harsh chemicals.
- Abrasive cleaning products such as tub and sink cleansers, scouring powder, scouring pads or steel wool.
- Sponges or dish clothes. They may contain particles that could scratch your cabinets, or they may contain food and oil residue.
- Solvent-based or petroleum-based products such as mineral spirits, nail-polish removers or paint thinners.
- Ammonia or cleaning products that include ammonia.
- Bleach or cleaning products that include bleach.
- Silicone-based cleaning, waxing, or polishing products.

CABINET REPAIR

REPAIRING SCRATCHES

Aristokraft dealers offer cabinet touch-up kits that include a touch-up marker, a filler pencil, and fast-

dry touch-up. It is important to follow the directions included with the kit. Aristokraft recommends the purchase of a touch-up kit to have on hand for minor repairs.

» Most cabinet scratches can be touched up using a matching touch-up marker available from your Aristokraft dealer. It is a waterbase pigmented marker for quick and easy coloring of wood surfaces. Directions: Shake well before using. Press tip 5-6 times to engage liquid. Once liquid flows to tip, apply in even strokes. Apply in one direction and do not over apply. Allow to dry before reapplying. Keep away from heat, sparks, and open flame. Use with adequate ventilation. **KEEP OUT OF THE REACH OF CHILDREN!!!** Harmful if swallowed. If swallowed, call physician immediately. Be sure to read instruction sheet for more details about this.

» For scratches or nicks that still show after using a touch-up marker, Aristokraft recommends using a filler pencil. Simply rub the pencil overfilling the scratched area and wipe away the excess with a clean soft cloth. Finally, apply a protective coating by using clear Fast Dry Touch Up (available from your Aristokraft dealer) or a clear acrylic spray (available in the paint section of your local hardware store).

CAUTION: Never use sandpaper or any other type of abrasive paper or material to "even out" a scratch. This will damage the cabinet finish.

LIMITED LIFETIME & 5 YEAR WARRANTY

Five Year Limited Warranty on Cabinets - Aristokraft warrants to original consumer purchasers for a period of five years from the original date of purchase that all other components of Aristokraft cabinetry shall be free from defects in material and workmanship under normal use.

Lifetime Limited Warranty on Drawer Guides and Hinges - Aristokraft warrants to original consumer purchasers for as long as they own their homes that the drawer box, drawer guides and hinges used in the manufacture of Aristokraft cabinetry products shall be free from defects in material and workmanship under normal use.

These warranties are only applicable to products used in residential applications within the United States and is not transferable to subsequent owners.

Should defects in material or workmanship exist during the applicable warranty period in any Aristokraft product, Aristokraft will elect at its discretion to either repair or replace the defective material or component free of charge. This warranty covers only parts and materials of the products supplied by Aristokraft. Not covered under this warranty are counter tops, appliances, plumbing fixtures, etc. or the costs, including labor, to remove and reinstall materials and related components such as fittings, appliances, etc.

This warranty shall become void if the cabinets are in any way modified, improperly installed or damaged prior to or during the installation. This also disclaims products utilized in any application other than the standard. Furthermore, this warranty will not apply to cabinets damaged by misuse, neglect, abuse, acts of God, exposure to moisture, exposure to extreme temperatures or the effects of normal wear and tear.

Natural woods may vary in color, characteristics and exhibit subtle changes as they age. Sunlight, smoke, household cleaners and other environmental conditions may also affect the color match over time. These variations are considered to be the nature of the material in relation to their environmental exposure and are not covered under this warranty.

Aristokraft reserves the right to alter design, specifications and material without obligation to make similar changes to products previously manufactured.

The repair(s) or replacement(s) are contingent upon

the current product offerings of styles and construction options within the Aristokraft product at the time of the warranty claim. If a warranty claim is filed after an Aristokraft product(s) becomes obsoleted, Aristokraft reserves the right to honor the warranty in one of the following fashions:

- » To replace the affected component with a new component of the same style.
- » To replace the affected component and any other component(s) in the residential application to achieve a uniform appearance with a similar and comparable product style of the originally purchased style.

If components are replaced, Aristokraft cannot guarantee that the finish of these replacements will exactly match the finish and appearance of the components in the residential application. This is due to the changes that occur during the woods' natural aging process, affecting its color and grain.

THIS WARRANTY IS THE EXCLUSIVE WARRANTY OF ARISTOKRAFT AND IS IN LIEU OF AND ARISTOKRAFT DISCLAIMS ALL OTHER WARRANTIES, EXPRESSED OR IMPLIED, INCLUDING THE IMPLIED WARRANTIES OF MERCHANTABILITY AND FITNESS FOR A PARTICULAR PURPOSE.

This warranty gives you specific legal rights and you may have other rights, which vary from state to state. Some states do not allow the exclusion or limitation of incidental or consequential damages, so the above limitations or exclusions may not apply to you.

To obtain replacement(s) under Aristokraft's Five Year and Lifetime Limited warranties, first contact your authorized Aristokraft Cabinetry dealer or distributor, who will arrange for inspection of the cabinet. A dated sales receipt as proof of purchase is required to obtain benefits from this warranty.

If you have difficulty obtaining assistance, please write to:

**Aristokraft, One MasterBrand Cabinets Drive,
P.O. Box 420, Jasper, IN 47547-0420.
Phone: (812) 482-2527 Fax: (812) 634-2838**

Aristokraft is a subsidiary of MasterBrand Cabinets, Inc.

IMPORTANT INFORMATION

Since no two trees are alike in grain or texture, "nature's fingerprint" is never the same in two pieces of wood; variations in color and grain are natural characteristics. Cabinet woods are stained to obtain as constant a tone as possible, while preserving the interest and charm. These grain patterns lend to the distinctive beauty of the cabinet.

Some Aristokraft door styles use solid wood raised center panels in the door construction. It is common that a small amount of expansion and contraction will occur depending on the season and amount of humidity.

THINGS TO AVOID

- » Avoid draping damp clothes or dishtowels over cabinet doors. This moisture can cause permanent damage — such peeling and discoloration — to the cabinet's finish.
- » The heat generated when using an oven's self-cleaning feature is much greater than during normal cooking. If this heat escapes from the oven, it can damage your cabinets. While this is a rare circumstance, you can minimize the risk of cabinet damage by removing cabinet doors and drawers nearest the oven or install heat shields before using its self-cleaning feature.
- » Exposure to direct sunlight tends to darken the color of natural wood products. Sunlight can also fade painted wood surfaces, laminated surfaces and thermofoil surfaces. You should consider draperies or blinds to shield your cabinets from direct sunlight.



Aristokraft Cabinetry meets or exceeds all strict performance and construction standards for kitchen and vanity cabinets set forth by the Kitchen Cabinet Manufacturers' Association

DOOR ALIGNMENT

» ADJUSTING CABINET DOOR ALIGNMENT

PROBLEM:
Doors are crooked.

SOLUTION:
Correct cabinet installation.

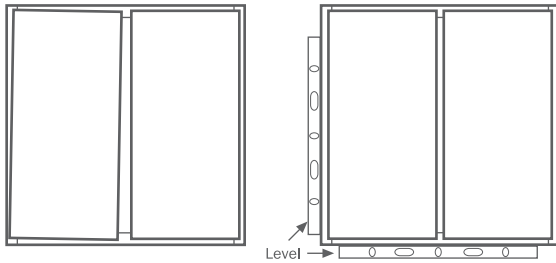

Cabinet doors that appear to be crooked and not line up with other doors could be a result of improper cabinet installation. It is essential that each cabinet be installed level and square, commonly referred to as "plumb." This can be checked by using a level on all vertical and horizontal surfaces of the cabinet. If during installation the cabinet is out of alignment, it can twist or become "racked," causing alignment problems. To correct this, loosen the cabinet from the wall and use shims to properly square up the cabinets. Shimming means inserting a tapered piece of wood or plastic behind or below the cabinet at the point of the gap.

PROBLEM:
Doors do not line up vertically.

SOLUTION:
Adjust hinges.

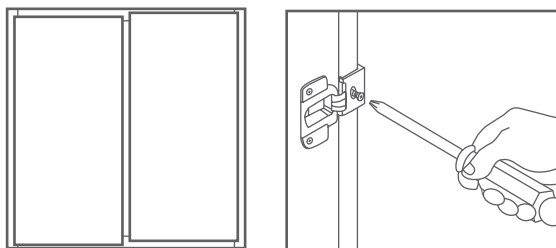

Loosen the hinge screws attaching the hinge to the door frame. Slide the door up or down until aligned, tighten screws.

» ADJUSTING SPACE BETWEEN TWO BUTT DOORS

PROBLEM:
Space between two adjoining butt doors is too great (exceeds 1/8").

SOLUTION:
Adjust hinges on full overlay doors. (See descriptions below).

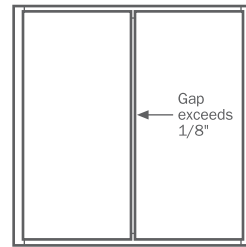

Cabinets featuring two doors that meet without a center section of cabinet frame are commonly called "butt" doors.

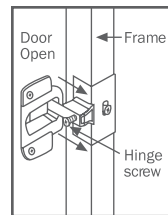

6-WAY ADJUSTABLE HINGE

The quantity of hinges varies depending on the cabinet height. Loosen the hinge screws on the arm of the hinges and slide the door toward the middle of the cabinet. Make sure the teeth on the hinge match up, then tighten the screws.

FULL OVERLAY DOORS

Overlap the cabinet frame completely.

PARTIAL OVERLAY DOORS

Partially overlap the cabinet revealing the cabinet frame.

DRAWER ALIGNMENT

» ADJUSTING CABINET DRAWER ALIGNMENT

PROBLEM:
Drawer does not close evenly.

SOLUTION:
Manually adjust drawer guide member.

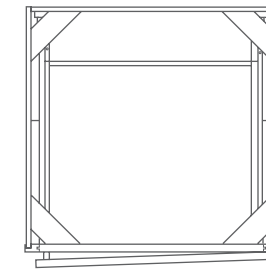

Overhead View

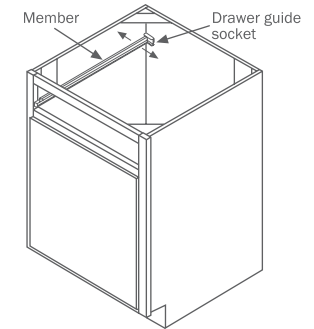

To correct drawer alignment, adjust the drawer guide member attached from the front edge of the cabinet to the back, by manually realigning the member in the back socket (member moves to the right and to the left about 1/2"). Once realigned, be sure to check that the drawer guide rollers stay in their track and operate smoothly.

SHELF ALIGNMENT

» ADJUSTING CABINET SHELVES

PROBLEM:
Shelf is sagging in the middle.

SOLUTION:
Use all shelf pegs in their proper position.

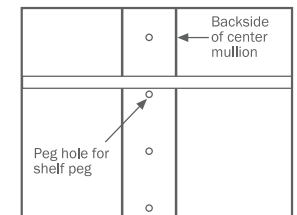
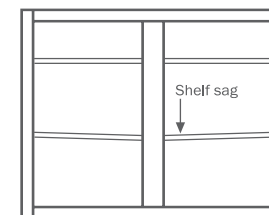

If a shelf starts to sag in the middle of a double door cabinet, be sure the shelf peg is inserted on the back side of the middle wood frame section between the double doors (center mullion). This is often overlooked.

PROBLEM:
Door does not close completely.

SOLUTION:
Adjust the shipping screw and bottom mounting bracket.

PROBLEM:
Door is crooked in frame and rubs against side frame.

SOLUTION:
Adjust screws in top and bottom adjustment slots.

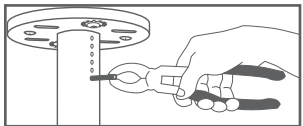

STEP 1
First, remove shipping pin with a pair of pliers.

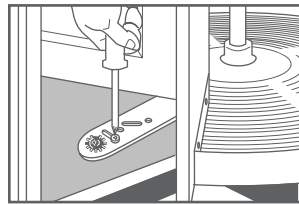
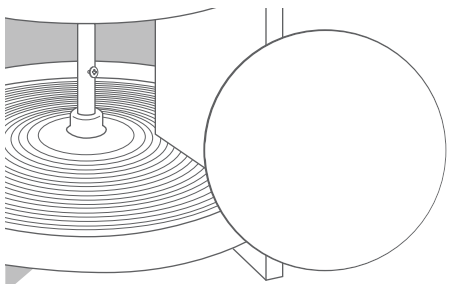

STEP 1
Open the doors so that one side of the bottom mounting bracket can be seen.

STEP 2
Remove the shipping screw and loosen the star-washer screw. If the door is out of alignment to the left, insert shipping screw into the right side of the slot as shown. Reverse if alignment is out to the right.

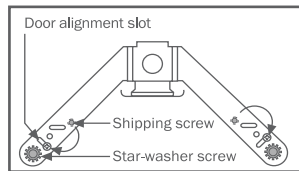

STEP 3
Repeat on both sides of bottom mounting bracket.

STEP 4
Rotate bracket to the left or right depending on which way the doors should go. Tighten the shipping screws in the door alignment slots and close the door to check alignment. Repeat if necessary.

STEP 5
After door has been aligned, tighten the star-washer screw.

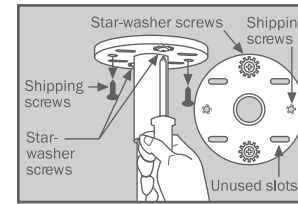

STEP 1
TOP ADJUSTMENT:
Remove two shipping screws. Loosen both front and back (star-washer) screws. Move the top mounting bracket until aligned vertically with

the sides of the cabinet to correct the gap between the side of the door and frame at the top. Tighten, check and repeat if necessary. Re-insert shipping screw in any unused hole or slot.

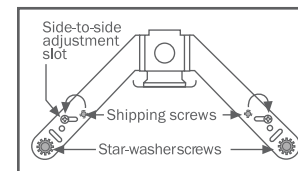

STEP 2
BOTTOM ADJUSTMENT:
Remove shipping screw if you have not done so. Loosen both star-washer screws on each side.

Move or shift the bottom mounting bracket until aligned vertically with the sides of the cabinet to correct the gap between the sides of the door and the frame at the bottom. Insert shipping screws in the side-to-side adjustment slots. Tighten, check and repeat if necessary. After door has been aligned, tighten the star-washer screws.